

PROVEN PERFORMANCE

Customers in over 50 countries and in diverse markets and sectors.



Kinco

VFD

Kinco KC100 high performance vector inverter



Kinco® Automation
en.kinco.cn Email: sales@kinco.cn

(All trademarks and logos in this brochure are property of and registered by their respective owners.)

K1E59-2407 K1E62

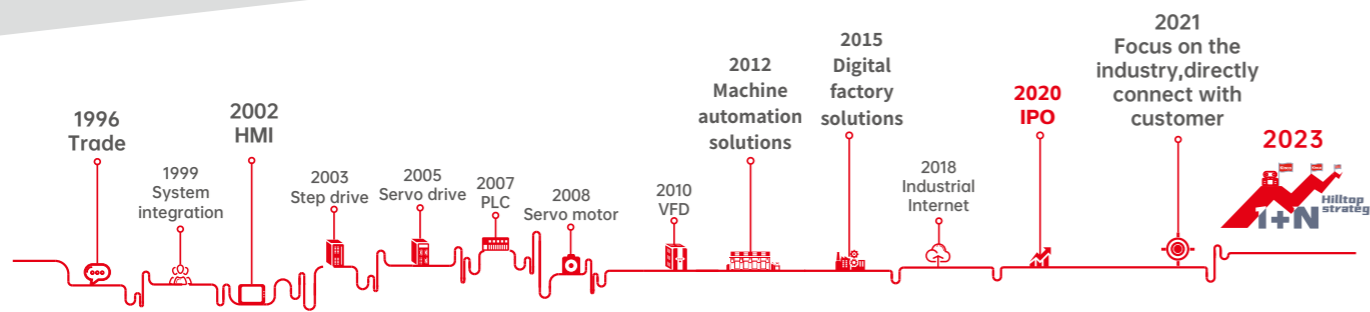

Shanghai Kinco Automation Co., Ltd. focuses on R&D, production, sales and technical services of automation standard products and intelligent hardware products, which is a leading supplier of machine automation and intelligent solutions for factories in China.

In 1996, Kinco has been providing total automation solutions for global industrial automation equipment manufacturers by relying on standard automation products such as HMI, servo system, stepping system, PLC, low-voltage inverter, etc. to penetrate into the industry, making China's automation solutions prevail all over the world. The company's HMI products have led the wave of HMI popularization in China, and its market share has maintained a leading position among local brand manufacturers for many years.

With the mission of "Making China's manufacturing become the top manufacturing in the world", Kinco company insists on investing a large amount of resources in the research and development of automated technology platforms, and sets up R&D facilities in Shanghai, Shenzhen and Changzhou. Kinco company has an automated technology platform that covers all aspects of control, drive, human-machine interaction, communication and electromechanical integration design. In the field of machine automation, Kinco focuses on the industry and has developed special solutions for logistics automation, service robots, medical instruments, professional drones, 3C machine tools, ozone and other industries.

In the field of smart factory, Kinco provides customers with the most easy-to-implement smart factory solutions for manufacturing companies at the field implementation level, PLC control and communication level, Scada and system integration level, and MES management level through its comprehensive automation technology platform and software system developed for smart factory.

With the vision of "creating a better life intelligently" and adhering to the values of "maintain conscience in growth and hold ingenuity in innovation", Kinco is a platform to help employees maximize their creative potential and a partner to help customers succeed in innovative management. We develop products and operate businesses with innovative thinking and practical spirit, adhere to ideals, and expect human creativity to make the world more wonderful.

KC100 series inverter

High performance vector inverter

Kc100 series inverter is a cost-effective product developed by Kinco based on a new technology platform. KC100 adopts narrow book-shape design, European crimping terminal and independent air duct design, which has many advantages such as convenient installation, convenient wiring, excellent heat dissipation, excellent performance and comprehensive protection. KC100 is systematic, process-oriented and strict in the development process of software, hardware and structure, paying attention to details and user experience. In the production and manufacturing process, KC100 relies on a complete quality process system to realize automatic tooling testing of all veneers and complete machines to ensure product quality.



Voltage level

Single-phase 220V model
0.4-2.2kW

Three-phase 380V model
0.75-5.5kW

Telecommunication

Support RS485 standard Modbus

Terminal configuration

4 * digital inputs	1 * analog input
1 * relay output	1 * analog output
1 * digital output	1 * RS485 communication

Industry applications

It can be widely used in sewage treatment, manufacturing production lines, fan ventilation systems, logistics and transportation, air conditioner cooling systems, woodworking machinery, and various automated production equipment and other industries.

- 02 Product Features
- 06 Naming rules & Parameters
- 07 Technical Specifications
- 08 Size drawing
- 09 Terminal wiring diagram & Function Description
- 10 Keyboard Operations
- EMC Filter selection

Product Feature

Product highlights

Compact structure , save space

Powerful Kinco software

Excellent suppression protection function

Excellent fault protection function

High quality

Compact structure , save space

- Narrow book-shape design, as small as 65mm, can be rail, vertical mounted; 20% less space than previous generations;
- European crimping terminal, 10 terminals without tightening screws, can improve assembly efficiency by 30%;
- Support network port connected to external keyboard and use standard MODBUS communication protocol and scheme.

Space Savings of 20%

Network port external keyboard

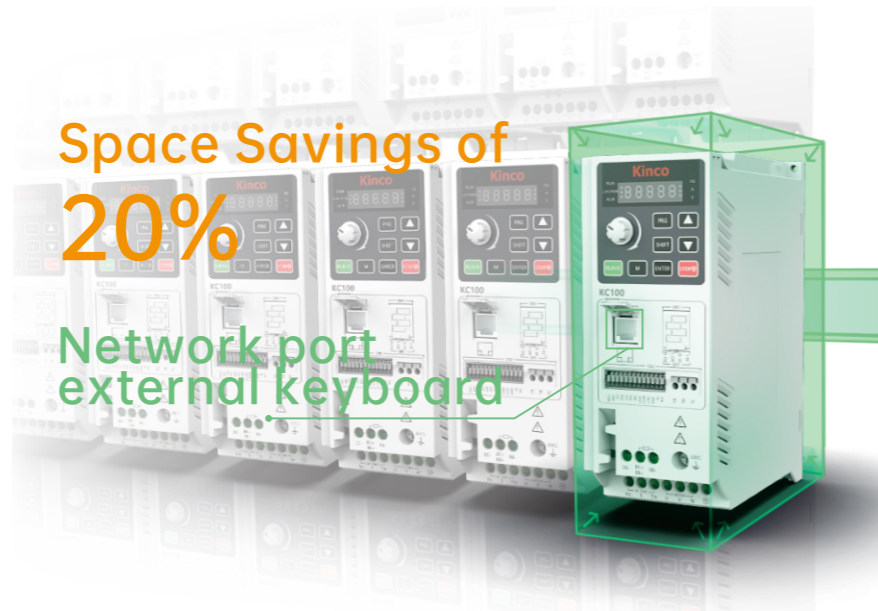

Product Feature

Powerful Kinco software

- Various frequency channel selections such as panel, analog, communication, pulse, PID, multi-speed, etc. Built-in AVR, over-modulation, instantaneous non-stop and other functional design, can adapt to complex grid environment; High-performance VF control algorithm that can achieve full speed range of rated frequency (except zero speed) with 150% load stable operation; High-performance SVC control for stable operation with 150% load over the full speed range of the rated frequency.

Open loop vector stable operation with 150% load in full speed range

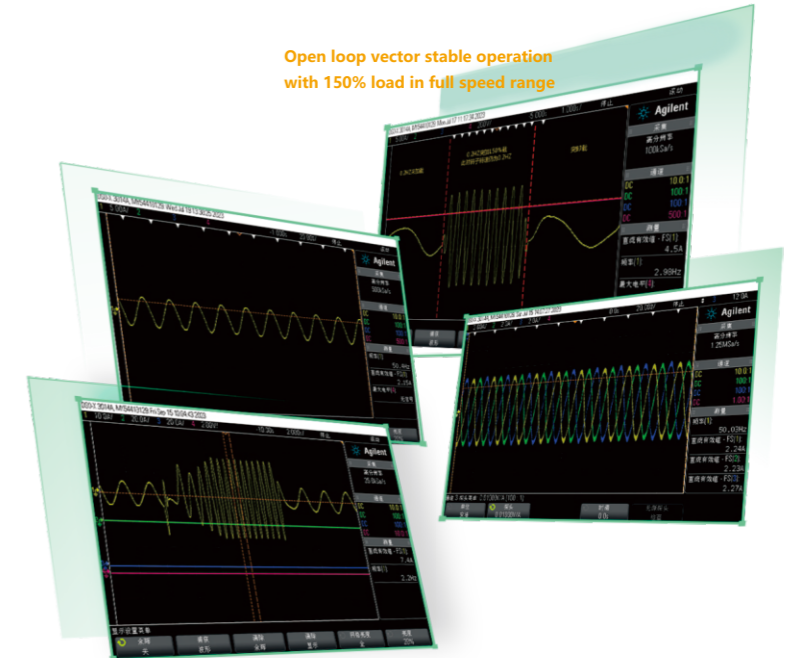

New high-performance vt control algorithm, stable operation at 0.1Hz with 150% load

Excellent suppression protection function

- **Overcurrent suppression protection** : real-time current monitoring, automatically limit the current to no more than the overcurrent suppression point;
- **Overvoltage suppression protection** : When no brake resistor is connected, the operating frequency is automatically adjusted or the bus voltage rise is suppressed by flux braking;
- **Undervoltage suppression protection (instantaneous non-stop)** : It can realize the function of instantaneous power loss without stopping;
- **Wave-by-wave current limiting** : When the sudden load or abnormal conditions such as momentary spikes in the current occurs, it will trigger the wave-by-wave current limit protection, which can limit the rise of the current to a certain extent, so that the current does not exceed the protection value of the inverter, and avoid reporting overcurrent fault and shutdown.
- **Heat dissipation treatment** : Independent air duct design, close to IGBT device, which can make cooling more efficiently, while the software built-in automatic reduction of carrier frequency according to temperature rise.

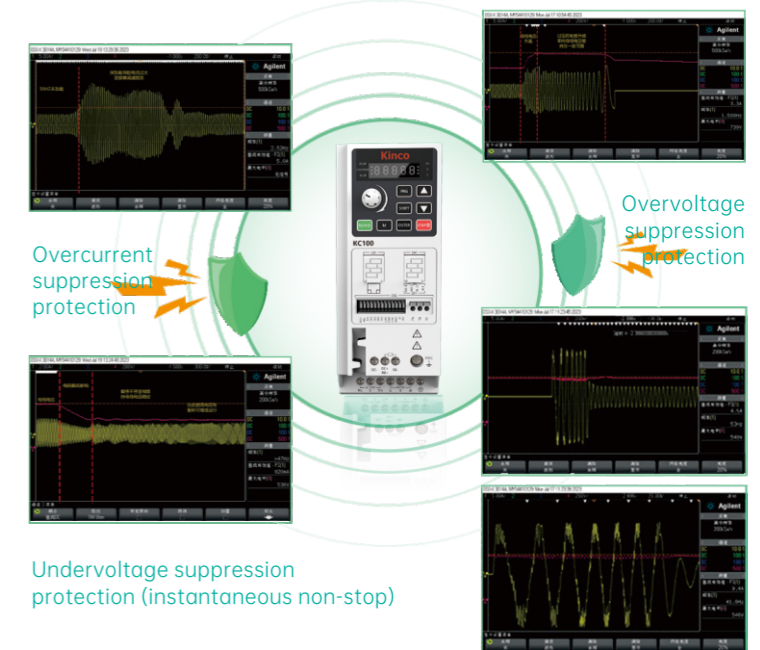

Overcurrent suppression protection

Overvoltage suppression protection

Undervoltage suppression protection (instantaneous non-stop)

Wave-by-wave current limiting

Product Feature

Excellent fault protection function

- Overvoltage, overcurrent fault protection;
- Input phase loss: Detect input phase loss based on bus voltage fluctuations. When phase loss occurs, a certain load is required to detect it;
- Output phase loss: Output phase loss fault can be quickly detected before and during operation;
- Phase to phase short circuit and short circuit to ground fault: quickly detected within 20ms before operation;
- Inverter module overtemperature, parameter self-learning failure, current detection failure.



High quality

- Fast delivery:**
Kinco digital smart factory, using a more advanced overall lean production layout and end-to-end quality management system, high production efficiency, to ensure fast delivery;
- 24h instantaneous response:**
Attach importance to customer experience and respond quickly to customer needs through multiple channels of quality service.



Naming Rules & Parameters

KC100 series inverter naming rules

KC100 - 2 S - 01R5 G

① ② ③ ④ ⑤

①-**Series**
KC100: KC100 Series

②-**Input voltage**
2: AC220V
4: AC380V

③-**Voltage level**
S: Single-phase 180V ~ 260V
T: Three-phase 320V ~ 460V

④-**Adaptive motor power**
01R5: 1.5KW
02R2: 2.2KW
.....
05R5: 5.5KW

⑤-**Adaptive load**
G: constant torque load

Note: R stands for decimal point

KC100 series inverter specifications and technical parameters

Inverter type	power capacity kVA	Input Current A	Output Current A	Adaptive motor kW
Single-phase 200V ~ 240V 50Hz/60Hz				
KC100-2S-0R40G	1.0	5.3	2.5	0.4
KC100-2S-0R75G	1.5	8.2	4.0	0.75
KC100-2S-01R5G	3.0	14.0	7.5	1.5
KC100-2S-02R2G	4.0	23.0	10.0	2.2
Three-phase 380V ~ 480V 50Hz/60Hz				
KC100-4T-0R75G	1.5	3.4	2.3	0.75
KC100-4T-01R5G	3.0	5.0	3.7	1.5
KC100-4T-02R2G	4.0	5.8	5.5	2.2
KC100-4T-03R7G	5.9	10.5	8.8	3.7
KC100-4T-05R5G	8.5	14.5	13.0	5.5

Technical Specification

KC100 series inverter technical specification

Item	Specification	
Power input	Rated voltage, Rated frequency	2S: single-phase 200V~240V 50Hz/60Hz; 4T: Three-phase 380V~480V 50Hz/60Hz
	Allowable fluctuation range of voltage	-15~10%
	Allowable fluctuation range of frequency	± 5%
Output	Output voltage	0~Input voltage
	Maximum output frequency	600Hz
	Overload capacity	60s at 150% the rated current, 3s at 180% rated current
Main control performance	Motor control mode	V/F control, Sensorless vector control (SVC), voltage frequency separation control
	Modulation mode	Space Vector Pulse Width Modulation
	Carrier frequency	0.5 kHz ~12.0 kHz
	Speed range	Open-loop vector control: rated load 1:200
	Startup torque	Open-loop vector control: 150% rated torque at 0.5Hz
	Torque response	Open-loop vector control: < 20ms
	Frequency accuracy	Digit setting: maximum frequency x (± 0.01%); Analog setting: Max frequency x (± 0.2%)
	Frequency resolution	Digital setting: 0.01Hz; Analog setting: maximum frequency x 0.1%
	Torque boost	Automatic torque improved ;manual torque improved 0.1%-30%
	Dc braking ability	Starting frequency: 0.00Hz ~ maximum frequency; Braking time: 0.0s ~ 100.0s; Brake current value: 0% ~ 150% rated current
Basic function of product	V/F curve	Four Methods: multi-point V/f curve; Reduced torque characteristic curve;
	Acceleration/ deceleration curve	Straight-line or S-curve acceleration/deceleration; Four groups of acceleration/deceleration time
	multi-speed running	The product supports up to 8 speeds with the control terminal
	Built-in PID	The function facilitates closed-loop control of process control.
	Fast current limit	Load regenerative energy compensates for voltage reduction during instantaneous power failure, When the mains voltage changes, the output voltage keeps constant automatically, allowing the AC drive to continue operating for a short time.
	Auto voltage regulation (AVR)	The function limits the current and voltage automatically during operation to prevent frequent trips caused by overvoltage or overcurrent. Running commands can be given through the operating panel, control terminal, or serial port communication.
	Power dip ride through	The function allows the inverter to continue operating during a power dip.
	Overvoltage/overcurrent stall control	The function allows the inverter to continue operating during a power dip.
	Running command	The function allows the inverter to continue operating during a power dip.
	Frequency reference	Digital, analog voltage, analog current, pulse and communication all have set.
Keyboard display	Auxiliary frequency reference	It can implement fine tuning of the auxiliary frequency and frequency synthesis.
	Input terminals	4* digital input terminals, 1 of which supports high-speed pulse input up to 50KHz
	Output terminals	1* analog input terminal, support 0 ~ 10V/0 ~ 20mA input 1* relay output terminal, including normally closed and normally open sub; 1* analog output terminal, support 0 ~ 10V voltage output 1* digital output terminal, 0.1kHz~50kHz pulse square wave signal output, capable of outputting physical quantities such as set frequency and output frequency
Environment	Network Port	1*RS485 communication External keyboard interface
	LED display	Single row 5-digit digital tube, with the same built-in keyboard and external keyboard
	Parameter copy	The external keyboard supports uploading and downloading the functional parameter information of the inverter to achieve fast parameter setting
	Condition monitoring	Can display setting frequency, output frequency, output voltage, output current and other more than 40 state parameters
	Fault Alarm	Overvoltage, undervoltage, overcurrent, short circuit, phase loss, overload, overheating, etc
	Installation site	In the altitude area of more than 1000 meters, due to the thin air caused by the poor heat dissipation effect of the inverter,
	Temperature	it needs to be derated, and 1% derated for every 100m rise
	Humidity	-10°C ~ + 50°C, please reduce using at + 40°C ~ +50°C
	Vibration	5%RH ~ 95%RH (non-condensation)
	Storage temperature	Less than 5.9 m/s ² (0.6g)
Over voltage level	- 20°C ~ + 60°C	
Class of contamination	OVC III	
Protection grade	Pd2	
Installation methods	lp20 Wall mounted	

Dimension Drawing

KC100 series inverter mechanical dimensions (mm)

Note: Please keep enough space when installing, the upper and lower space is recommended to keep >100mm, the left and right space is recommended to keep > 25mm

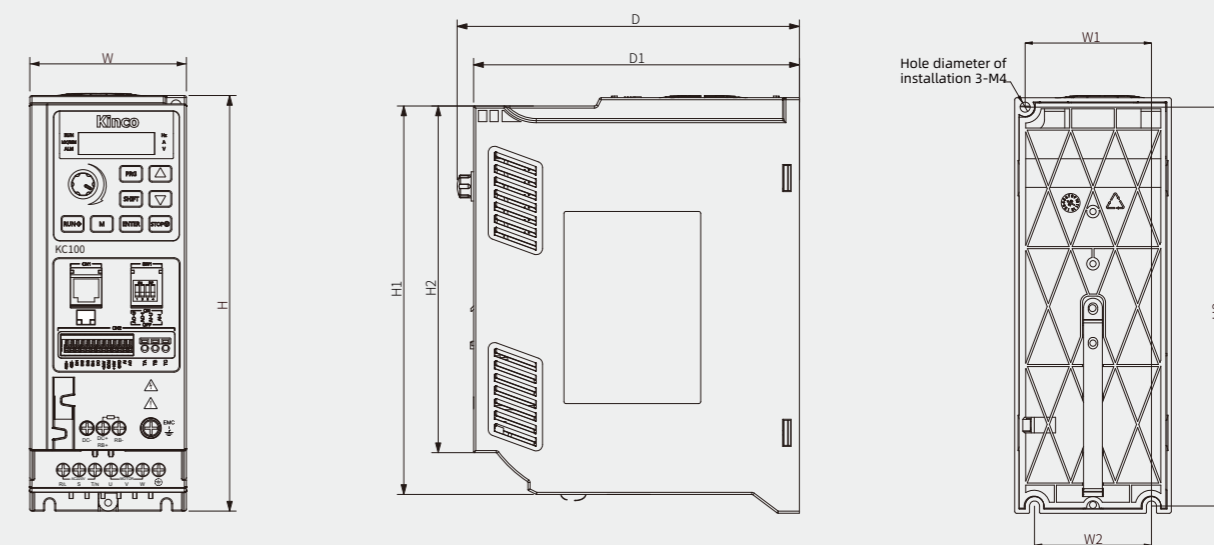

Voltage level	Model	Power (KW)	Dimension (mm)					Mounting hole location (mm)			Hole diameter of installation (mm)	Weight (kg)	
			W	H	H1	H2	D	D1	W1	W2			H3
One-phase 220VAC	KC100-2S-0R40G	0.4	65	177	168.5	145	148	139	50	45	168	3-M4	0.85
	KC100-2S-0R75G	0.75											
Three-phase 380VAC	KC100-4T-0R75G	0.75	75	199	190	166	163	156	60.5	56	191	3-M4	1.20
	KC100-4T-01R5G	1.5											

Voltage level	Model	Power (KW)	Dimension (mm)					Mounting hole location (mm)			Hole diameter of installation (mm)	Weight (kg)	
			W	H	H1	H2	D	D1	W1	W2			H3
One-phase 220VAC	KC100-2S-01R5G	1.5	75	199	190	166	163	156	60.5	56	191	3-M4	1.28
	KC100-2S-02R2G	2.2											
Three-phase 380VAC	KC100-4T-02R2G	2.2	75	199	190	166	163	156	60.5	56	191	3-M4	1.28
	KC100-4T-03R7G	3.7											
	KC100-4T-05R5G	5.5											

Terminal wiring diagram & Function description

KC100 series terminal wiring diagram

The dotted line shows the power wiring diagram of the three-phase and single-phase types, please wiring according to the actual model.

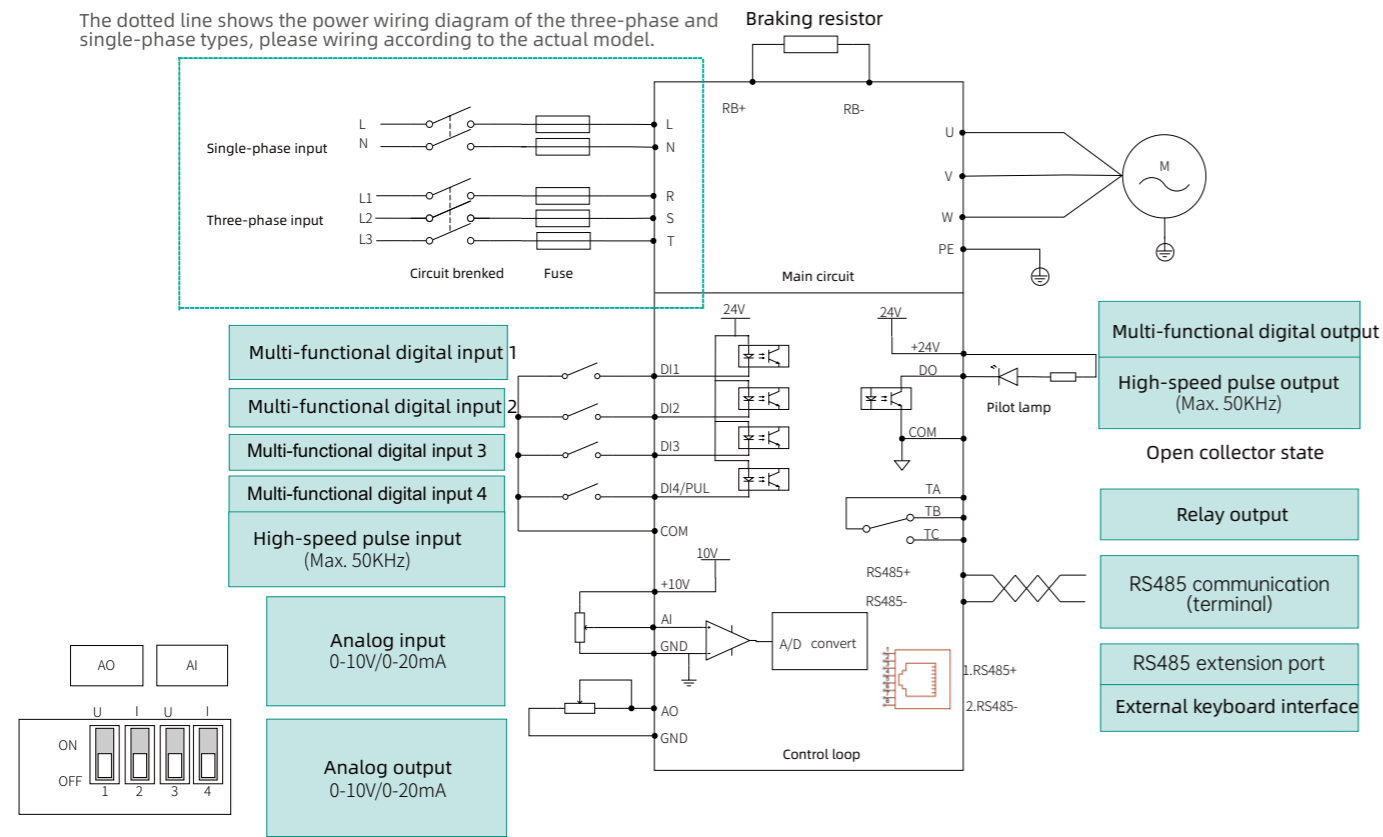

KC100 series terminal function description

Terminal type	Terminal signal	Terminal name	Terminal function description
Main circuit	R/L, S, T/N	Three-phase/single-phase input terminals	Connect to the grid
	U, V, W	Three-phase output terminal	Three-phase AC output, connecting motor
	DC-	Negative end of DC	Common DC bus use
	DC+(RB+)	DC+ RB+	Dc bus plus end Brake resistor wiring end
Control circuit	RB-	Brake resistor wiring end	Shield the ground terminal
	⊕	Ground terminal	Shield the ground terminal
	DI1-DI4	Multifunctional digital input	Active low Effective level:0 ~ 15VDC; DI1-DI3 is low speed input; DI4 is used as a high speed; input with a maximum input frequency of 50kHz.
	DO	High-speed pulse output	High speed pulse output; Maxoutput frequency 50kHz, Also as an open collect output
	+ 24V	+ 24V	External 24VDC power supply; Output voltage range:24V ± 10%; Maximum current: 200mA Interior isolated from GND
	COM	24V power supply ground	Interior isolated from GND
	+10V	+10V analog voltage output	External 10V analog power supply; Output voltage range:10V ± 10%; Maximum current: 10mA Interior isolated from COM
	GND	Simulated ground	Interior isolated from COM
	AI	Analog input	Input voltage/current range:0 ~ 10V/0 ~ 20mA; Select input signal type by dial switch
	AO	Analog output	Support 0 ~ 10V/0 ~ 20mA; Output Select the output signal type through the dial switch
	TA-TB-TC	Relay output	Normally closed: TA-TB; Normally open: TA-TC Contact load: 3A/250V AC, 1A/30V DC
	485+	485 communication positive signal	RS485 communication, support standard MODBUS RTU protocol
	485-	485 Communication negative signal	

Keyboard Operation

Keyboard operation

Support built-in keyboard and external keyboard, the body keyboard adopts 8 large-size independent keys, no multiplex keys, can avoid the possibility of mispressing easy and quick to achieve control functions, using potentiometer and external keyboard, keyboard cable up to 10 meters.

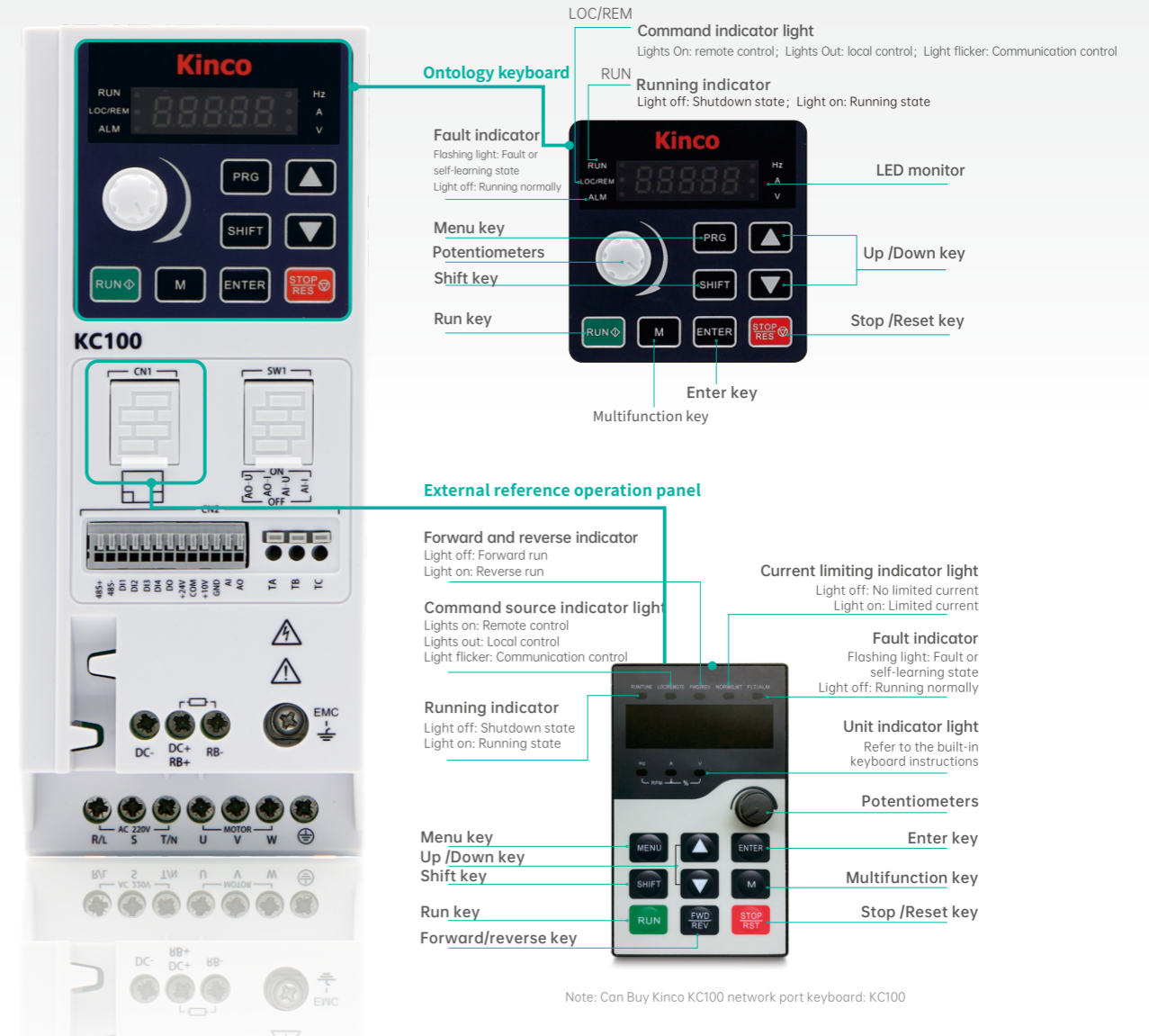

Note: Can Buy Kinco KC100 network port keyboard: KC100

EMC Filter selection

Model	Power (kW)	Specification	Rated current (A)	Order number
Single-phase 200V~240V 50Hz/60Hz				
KC100-2S-0R40G	0.4	ME440-5	5	18.2.01.0216
KC100-2S-0R75G	0.75	ME440-10	10	18.2.01.0215
KC100-2S-01R5G	1.5	ME440-20	20	18.2.01.0214
KC100-2S-02R2G	2.2	ME440-20	20	18.2.01.0214
Three-phase 380V~480V 50Hz/60Hz				
KC100-4T-0R75G	0.75	ME466-5	5	18.2.01.0211
KC100-4T-01R5G	1.5	ME466-5	5	18.2.01.0211
KC100-4T-02R2G	2.2	ME466-10	10	18.2.01.0212
KC100-4T-03R7G	3.7	ME466-10	10	18.2.01.0212
KC100-4T-05R5G	5.5	ME466-20	20	18.2.01.0213