

Mini installation beacon / MC55  
**MC55 UL Beacon 10-30V RGB M12**



Part No.:	240.320.50
Series:	MC55



MECHANICAL DATA	
Height	71 mm
Diameter	55 mm
Materials	PC
Dome colour	Tranlucent
Housing colour	Black
Protection category	IP69K
Connection	M12 plug 5-pole
Type of fixing	Built-in mounting
Working temperature minimum	-20°C
Working temperature maximum	+50°C
Weight with packaging	93 g
Product weight	66 g

ELECTRICAL DATA	
Operating voltage	10-30V
Operating voltage type	DC
Operating voltage tolerance	+/- 0%
Rated operational voltage	24 VDC
Rated operational current	120 mA
Rated inrush current	<700mA
Protection class	Protection class 2
Pollution degree	3 In the connection area: 2
Overvoltage category	I
Isolation voltage	Ui = 50V / Uimp = 330V

OPTICAL DATA	
Light source	LED
Light colour	MC 7 colours
Optical signal image	Permanent
Service life optical	50,000 h maximum

APPROVAL DATA	
Conforms with CE	Yes
WEEE	Yes
Conforms with CCC	No
Conforms with UL	cULus
UL Type Rating	Type 4X
Conforms with FCC	No



For additional installation and mounting information, refer to the appropriate user guide at [www.werma.com](http://www.werma.com). This printed copy is for information only and is subject to alteration.

Mini installation beacon / MC55

**MC55 UL Beacon 10-30V RGB M12**

Conforms with IC	No
EAC certificate available	No
Conforms with UKCA (Importer)	Yes (WERMA (UK) Ltd.)
Conforms with AS-I	No
Conforms with DNV	No
Conforms with RoHS CN	25 years
Conforms with VdS	No
MTTF-value [years]	133

**DRAWING**

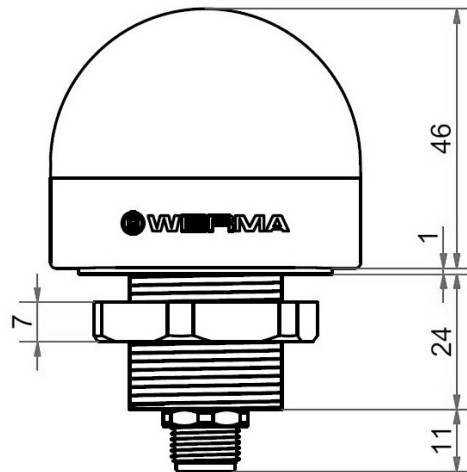
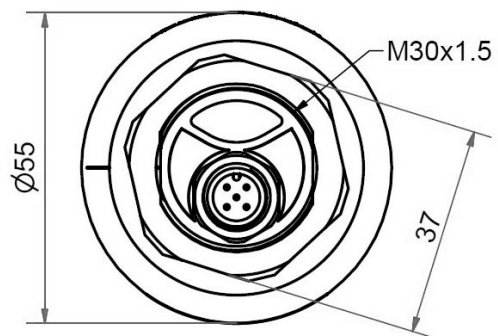

! For additional installation and mounting information, refer to the appropriate user guide at [www.werma.com](http://www.werma.com). This printed copy is for information only and is subject to alteration.