

Mini installation beacon / MC55  
**MC55 RGB M12-plug 10-30VDC**



Part No.:	240.120.50
Series:	MC55



MECHANICAL DATA	
Height	71 mm
Diameter	55 mm
Materials	PC PC/ABS
Dome colour	Translucent
Housing colour	Black
Protection category	IP65
Connection	M12 plug 5-pole
Cable length	100 mm
Tension relief	Pull-out protection
Type of fixing	Built-in mounting
Working temperature minimum	-20°C
Working temperature maximum	+50°C
Weight with packaging	98 g
Product weight	70 g

ELECTRICAL DATA	
Operating voltage	10-30V
Operating voltage type	DC
Operating voltage tolerance	+/- 0%
Rated operational voltage	24 VDC
Rated operational current	60 mA
Rated inrush current	<700mA
Protection class	Protection class 2
Pollution degree	3 In the connection area: 2

OPTICAL DATA	
Light source	LED
Light colour	MC 7 colours
Optical signal image	Permanent
Service life optical	50,000 h maximum

APPROVAL DATA	
Conforms with CE	Yes
WEEE	Yes
Conforms with ATEX-directive	No
Conforms with CCC	No
Conforms with UL	No
Conforms with FCC	No



For additional installation and mounting information, refer to the appropriate user guide at [www.werma.com](http://www.werma.com). This printed copy is for information only and is subject to alteration.

Mini installation beacon / MC55

**MC55 RGB M12-plug 10-30VDC**

Conforms with IC	No
EAC certificate available	Yes
Conforms with UKCA (Importer)	Yes (WERMA (UK) Ltd.)
Conforms with AS-I	No
ICAO Certification	No
Conforms with DNV	No
Conforms with RoHS CN	25 years
Conforms with VdS	No
MTTF-value [years]	133

**DRAWING**

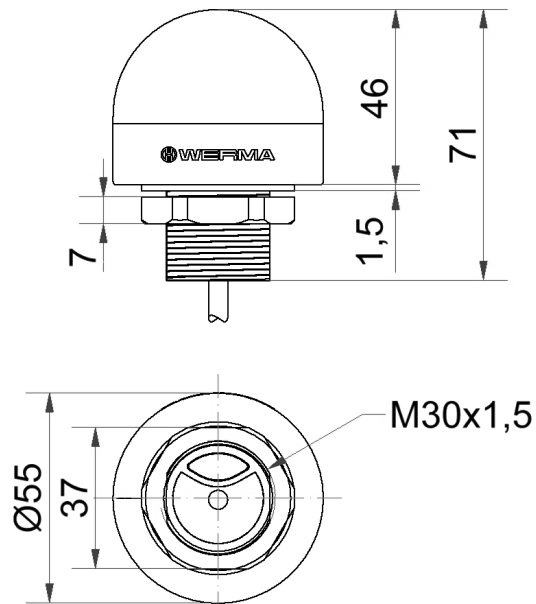

! For additional installation and mounting information, refer to the appropriate user guide at [www.werma.com](http://www.werma.com). This printed copy is for information only and is subject to alteration.