

Signal lights / 808/809/818

LED Perm. Beacon RM 230VAC BU



Part No.: 808.569.68



MECHANICAL DATA	
Height	117 mm
Diameter	71 mm
Materials	PC PC/ABS
Dome colour	Blue
Housing colour	Black
Protection category	IP65
cross-sectional area minimum	0,34mm ² / 22AWG
cross-sectional area maximum	2,50mm ² / 14AWG
Cable entry	Through hole
Tension relief	Pull-out protection
Type of fixing	Tube mounting
Working temperature minimum	-30°C
Working temperature maximum	+50°C
Weight with packaging	108 g
Product weight	108 g
ELECTRICAL DATA	
Operating voltage	230V
Operating voltage type	AC
Operating voltage frequency	50Hz
Operating voltage tolerance	+/- 10%
Rated operational voltage	230 VAC
Rated operational current	20 mA
Rated inrush current	1.500 mA
Protection class	Protection class 2
Pollution degree	3
Overvoltage category	II
Isolation voltage	U _i = 250V; U _{imp} = 2.500V
OPTICAL DATA	
Light source	LED
Light colour	Blue
Optical signal image	Permanent
Service life optical	50,000 h maximum
APPROVAL DATA	
Conforms with CE	Yes
WEEE	Yes

! For additional installation and mounting information, refer to the appropriate user guide at www.werma.com. This printed copy is for information only and is subject to alteration.

Signal lights / 808/809/818

LED Perm. Beacon RM 230VAC BU

Conforms with ATEX-directive	No
Conforms with CCC	Yes
Conforms with UL	No
Conforms with FCC	No
Conforms with IC	No
EAC certificate available	No
Conforms with UKCA (Importer)	Yes (WERMA (UK) Ltd.)
Conforms with AS-I	No
ICAO Certification	No
Conforms with DNV	No
Conforms with RoHS CN	25 years
Conforms with VdS	No

DRAWING

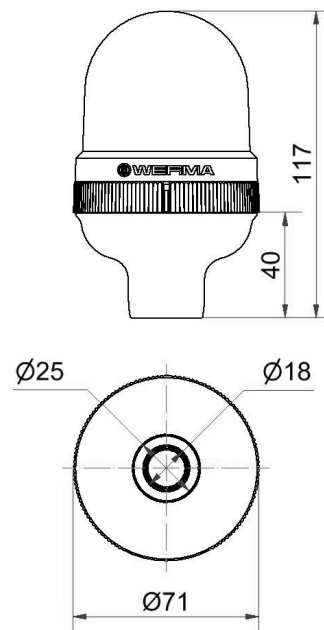

! For additional installation and mounting information, refer to the appropriate user guide at www.werma.com. This printed copy is for information only and is subject to alteration.